

## Quality Packaged Steel Boiler Systems

ALSTROM Boiler Series AISB3, steel scotch marine, horizontal firetube 3-Pass packaged combustion systems are manufactured for use in low pressure steam (to 15 PSIG) or hot-water (30 to 160 PSIG, maximum 250 degrees F) applications, providing for efficient operation and low cost maintenance. Complete packaged units piped, wired and ready for years of reliable low cost maintenance efficient operation. Packaged boiler assemblies meet ASME, UL and ASHRAE 90.1 and available with many brands of automatic fuels burning systems.

Front and rear tubesheet access doors provide for quick and easy maintenance procedures. Furnace access accomplished through large rear manhole door. Minimum refractory material further provides reduced maintenance, repair and/or replacement costs.



Series AISB3 boilers are rated at 5 sq. ft. of fireside heating surface per boiler horsepower permitting long service life, are designed and constructed in accordance with ASME Section IV latest edition, and fully jacketed to assure high thermal efficiency utilizing 2" thick insulating material. Large furnace volume permits low heat release rate and low static pressure allow for reduced fuel burning equipment electrical horsepower requirements.

Natural or propane gas, fuel oil # 2-6 and/or combination gas/oil fuel burning systems are available to suit any applicable standards, such as UL, IRI, FM, ASME CSD, and particular specification requirements.



11 Jocama Blvd., Suite 11A  
Old Bridge, NJ 08857 USA  
**718-824-4901**  
info@alstromboilers.com

Represented by:



# Series AISB3 Boilers

THREE PASS WATERBACK DESIGN

LOW PRESSURE STEAM UP TO 15 PSIG

HOT WATER UP TO 160 PSIG, 250 DEG. F

ASME SECTION IV LOW PRESSURE HEATING BOILERS

CAPACITY FROM 50 TO 600 BHP

PACKAGED WITH GAS, OIL OR COMB. GAS/OIL BURNERS

LARGE FURNACE VOLUME, LOW HEAT RELEASE RATE

COMPLIES WITH ASME, UL, CSD-1 & ASHRAE STANDARDS

## Quality Packaged Boiler Systems

Heat Transfer Equipment & Systems since 1939

ALSTROM Energy Group LLC Series AISB3, steel scotch marine, horizontal firetube 3-pass waterback boilers are manufactured for use in low-pressure steam (15 PSIG) or hot-water (30 to 160PSIG, maximum 250 degrees F) applications, providing for efficient operation and low cost maintenance. Complete packaged units piped, wired and ready for years of reliable low cost maintenance efficient operation. ASME & UL approved with many brands different fuels automatic burners. Boilers are available with advanced emission reduction technology to meet any modern specifications.



[www.alstromboilers.com](http://www.alstromboilers.com)

# Series AISB3 Boilers Rating Data General Dimensions

# Series AISB3 Boilers Rating Data

SERIES AISB3 BOILER HP	50	60	70	80	90	100	125	150	175	200	250	300	350	400	450	500	600
<b>A</b> INSIDE DIAMETER - SHELL	55	55	55	55	55	63	63	63	84	84	84	84	96	96	96	108	108
<b>B</b> INSIDE DIAMETER - FURNACE	27	27	27	27	27	30	30	30	37-1/4	37-1/4	37-1/4	37-1/4	47	47	47	57	57
<b>C</b> LENGTH OF BASE	106	121-3/4	137	150	165.25	140	182	208	143	158	200	220	220	242	264	202	247
<b>D</b> NORMAL WATER LINE	62-1/2	62-1/2	62-1/2	62-1/2	62-1/2	66-3/4	66-3/4	66-3/4	83-1/4	83-1/4	83-1/4	83-1/4	94-1/4	94-1/4	94-1/4	105-3/4	105-3/4
<b>E</b> C.L. OF FURNACE	35-1/4	35-1/4	35-1/4	35-1/4	35-1/4	36-1/4	36-1/4	36-1/4	43-1/8	43-1/8	43-1/8	43-1/8	51-1/8	51-1/8	51-1/8	56-5/8	56-5/8
<b>F</b> BOILER HEIGHT -OVERALL	79-1/8	79-1/8	79-1/8	79-1/8	79-1/8	88-1/8	88-1/8	88-1/8	111	111	111	111	123	123	123	135	135
<b>G</b> BOILER LENGTH -OVERALL	135-1/2	151-1/4	166-1/2	179-3/4	195	167-3/4	209-3/4	235-3/4	182	197	239	259	263	285	307	256	301
<b>H</b> LENGTH OF SHELL	105	120-3/4	136	150	165-1/4	135-3/4	159-3/4	185-3/4	131	146	171	191	196	218	240	188	233
<b>I</b> RETURN LOCATION	47	47	59	59	59	59	59	59	59	59	59	59	63	63	63	77	77
<b>J</b> HEIGHT - FRONT SMOKEBOX	64-1/4	64-1/4	64-1/4	64-1/4	64-1/4	68-1/2	68-1/2	68-1/2	85-1/8	85-1/8	85-1/8	85-1/8	96-1/8	96-1/8	96-1/8	107-3/8	107-3/8
<b>K</b> SUPPLY LOCATION	38	38	46	46	46	48	48	48	53	53	53	53	82	82	82	81	81
<b>L</b> STEAM SUPPLY SIZE (NPS)	6	6	6	6	6	8	8	8	8	8	10	10	10	10	10	12	12
<b>M</b> WATER SUPPLY SIZE (NPS)	3	3	4	4	4	4	4	6	6	6	6	6	6	8	8	8	8
<b>N</b> VENT DIAMETER	12-3/4	12-3/4	12-3/4	12-3/4	12-3/4	18	18	18	20	20	20	20	26	26	26	32	32
<b>O</b> FRONT SKID EXTENSION	24	24	24	23	23	23	41	41	41	41	58	58	54	54	54	52	52
<b>P</b> LENGTH -REVERSING CHAMBER	18-3/4	18-3/4	18-3/4	18-3/4	18-3/4	18-3/4	18-3/4	18-3/4	32	32	32	32	32	32	32	38	38
<b>Q</b> STEAM RETURN SIZE (NPS)	4	4	4	4	4	4	4	4	4	4	4	4	6	6	6	6	6
<b>R</b> WATER RETURN SIZE (NPS)	3	3	4	4	4	4	4	6	6	6	6	6	6	6	8	8	8
<b>S</b> LENGTH OF FURNACE	65	80-3/4	96	110	125-1/4	95-3/4	119-3/4	145-3/4	58-1/2	73-1/2	98-1/2	118-1/2	134-1/2	156-1/2	178-1/2	117-1/2	162-1/2
<b>T</b> FRONT DOOR SWING	27	27	27	27	27	30	30	30	36	36	36	36	42	42	42	48	48
<b>U</b> REAR DOOR SWING	16	16	16	16	16	19	19	19	24	24	24	24	29	29	29	35	35
<b>V</b> TUBE PULL	83	99	113	127	142	113	137	163	109	124	149	169	166	188	210	154	199

BOILER SIZE, Series AISB3	HP	50	60	70	80	90	100	125	150	175	200	250	300	350	400	450	500	600
<b>Steam Output; From @ 212 F</b>	<b>LBS/HR</b>	1725	2070	2415	2760	3105	3450	4313	5175	6038	6900	8625	10350	12075	13800	15525	17250	20700
<b>Gross Output</b>	<b>MBH</b>	1674	2009	2343	2678	3013	3348	4184	5021	5858	6695	8369	10043	11716	13390	15064	16738	20085
<b>Firing Rate Natural Gas; 1,000 BTU/CF</b>	<b>CFH</b>	2092	2511	2929	3348	3766	4184	5230	6277	7323	8369	10461	12553	14645	16738	18830	20922	25106
<b>Firing Rate Fuel Oil#2; 140,000 BTU</b>	<b>GPH</b>	15	18	21	24	27	30	37	45	52	60	75	90	105	120	135	150	179
<b>Firing Rate Fuel Oil#6; 150,000 BTU</b>	<b>GPH</b>	14	17	20	22	25	28	35	42	49	56	70	84	98	112	126	139	167
<b>Fireside Heating Surface</b>	<b>SQ FT</b>	250	300	350	400	450	500	625	750	875	1000	1250	1500	1750	2000	2250	2500	3000
<b>Furnace Volume</b>	<b>CU FT</b>	35	40	45	50	56	57	67	78	78	106	123	136	198	221	244	265	334
<b>Heat Release</b>	<b>MBH/ FT^3</b>	60	63	65	67	68	74	78	80	80	79	85	92	74	76	77	79	75
<b>Operating Volume</b>	<b>GPH</b>	438	531	620	704	793	649	799	962	962	1274	1565	1798	2059	2356	2652	2975	3910
<b>Approx. Shipping Weight</b>	<b>LBS</b>	3922	4534	5121	5670	6257	8151	9355	10660	10660	14055	16001	17558	21910	24031	26151	29647	35918
<b>Approx. Operating Weight</b>	<b>LBS</b>	7572	8961	10295	11541	12874	13560	16020	18686	18686	24676	29053	32555	39083	43677	48270	54455	68528
<b>Approx. Flooded Weight</b>	<b>LBS</b>	8015	9492	10909	12233	13651	15701	18626	21794	21794	28084	33166	37232	47033	52701	58370	63925	80824

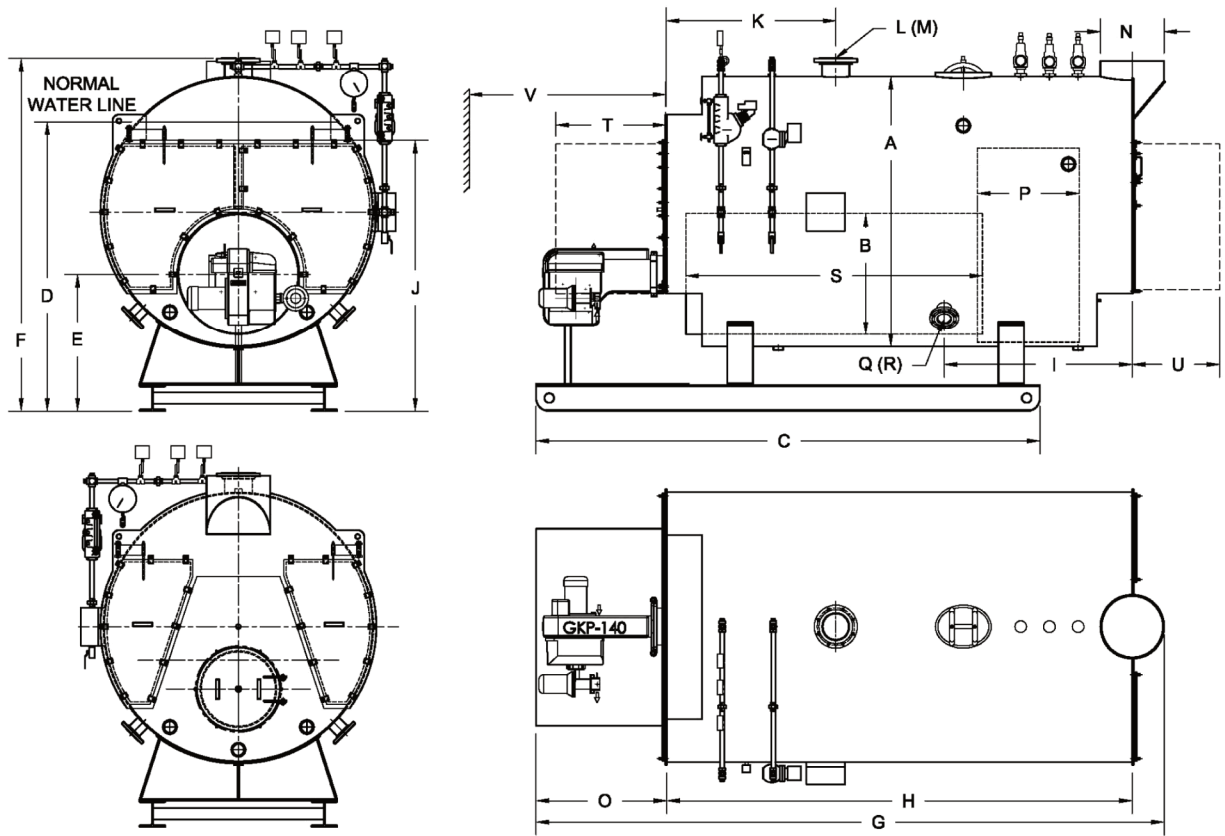

**ALSTROM Energy Group LLC**  
 11 Jocama Blvd., Suite 11A, Old Bridge NJ 08857 USA  
 p. 718-824-4901 f. 718-409-3605 e. info@alstromboilers.com

**NOTES:**  
 ALL DIMENSIONS ARE IN INCHES, CERTIFIED DRAWING AVAILABLE UPON REQUEST.  
 DIMENSIONS SUBJECT TO CHANGE WITHOUT NOTICE.