

Hot Water Generator Series "ASH-V"

U.S. PATENT NUMBER 6,101,984

ACTUAL LOCATION OF ACCESSORIES IS PROVIDED BY CERTIFIED DRAWING UPON RECEIPT OF ORDER.

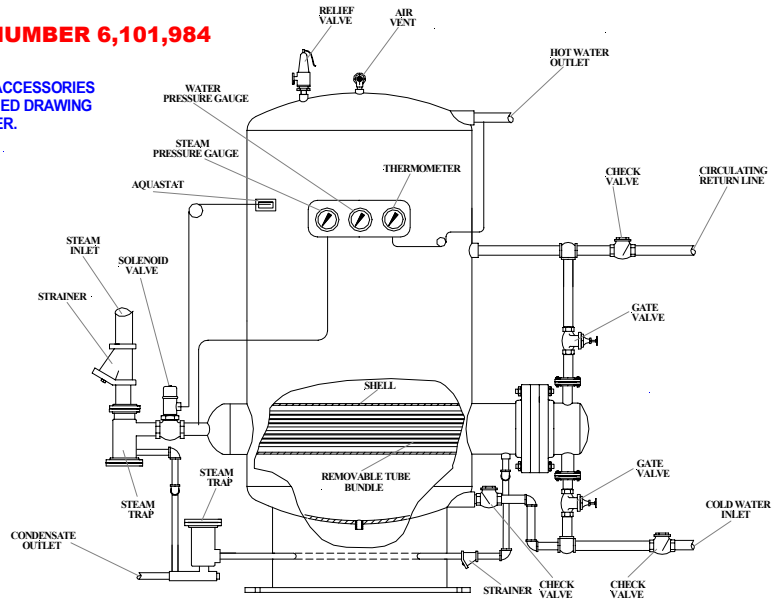

	STORAGE TANK	HEAT EXCHANGER
MATERIALS	316L STAINLESS STEEL	316L STAINLESS STEEL
DESIGN PRESSURE	125 psig	150 psig
DESIGN TEMPERATURE	400 F	400 F

The Alstrom Compact Water Heater combines the advantages of both instantaneous and storage heaters. The package is constructed from a vertical storage tank and a built-in shell & tube heat exchanger. Steam, hot water or heat transfer fluid passes through the shell of the heat exchanger. City water is heated by forced convection in the tubes of the heat exchanger and enters the storage tank. When the consumption of hot water stops, the heat losses are compensated by natural convection heat transfer between the external surface of the heat exchanger's shell and stored water. In addition, the heated water is circulating between the heat exchanger and the storage tank by natural convection, **eliminating the need for recirculating pump**. This system's design permits **fast cleaning, repair and replacement of the tube bundle without draining the water from the tank**. The storage tank is already full of **heated water that is available to the user during the shutdown**. Unique features of this system **reduce it's price and maintenance expenses while making it more reliable**. Model "ASH-V" stores water at 140 deg. F (other storage temperatures are optional). A small tank with a large heat transfer section is used as a semi-instantaneous heater.

Optional Double Wall Tube Bundle prevents cross-contamination of water used in potable Hot Water Storage systems

Vented double wall construction for use on potable water systems. Unique diamond shape pattern provides multiple vented leak ports for positive indication of potential contamination. Double wall tubes are available on "ASH" Series Hot Water Generator. Double wall tube options include Copper, 90/10 Cu-Ni, and 316 SS materials.

Double Wall heat exchangers are designed to give a positive indication of potential cross-contamination of potable water and other liquids in an economical and thermally efficient way.

Heat transfer section of this double wall heat exchanger is available for "ASH" series.

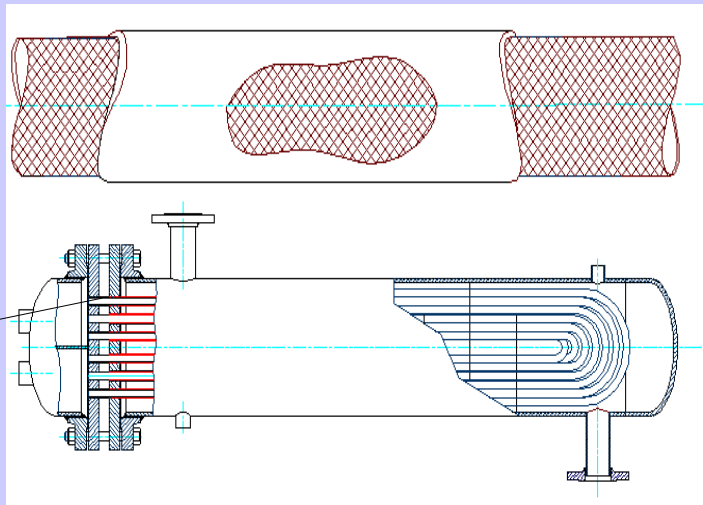
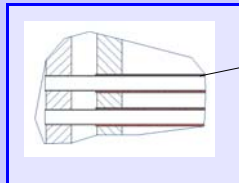

VERTICAL STORAGE TANK DIMENSIONS IN INCHES

TANK SIZE	STORAGE CAPACITY IN GALLONS	TANK DIAMETER	TANK OVERALL HEIGHT	SIZE OF WATER INLET & OUTLET	TANK SIZE	STORAGE CAPACITY IN GALLONS	TANK DIAMETER	TANK OVERALL HEIGHT	SIZE OF WATER INLET & OUTLET	TANK SIZE	STORAGE CAPACITY IN GALLONS	TANK DIAMETER	TANK OVERALL HEIGHT	SIZE OF WATER INLET & OUTLET
1ASH-V	170	30	84	1-1/2	5ASH-V	392	36	120	2	9ASH-V	865	48	144	3
2ASH-V	240	30	108	1-1/2	6ASH-V	460	42	108	2	10ASH-V	1300	60	144	4
3ASH-V	284	36	96	1-1/2	7ASH-V	530	42	120	2-1/2	11ASH-V	1980	72	144	4
4ASH-V	338	36	108	2	8ASH-V	680	48	120	2-1/2	CUSTOM				